

Technical specifications

Diesel Generator Set

Frequency: 50HZ

QES 520

Voltage: 400/230 V

Frequency: 50HZ



Genset Image for illustration purposes only

TECHNICAL INFORMATION

Standby Power (ESP)	kVA	531
	kW	425
Prime Power (PRP)	kVA	515
	kW	412
Rated current 3ph (PRP)	A	743
Mechanical structure		Soundproofed
Engine		Cummins QSZ13-G3
Alternator		ATLASCOPCO ACA355C
Control card		DEEP SEA 7320
Measures (L x W x H) mm 2.220	mm	4600 x 1500 x 2350
Empty weight	kg	5100
Fuel tank	L	740
Acoustic pressure, LpA	dB(A) @ 7m	74
Acoustic power LwA	dB(A)	102

Voltages	Prime Power (PRP)		Standby Power (ESP)	
	(kVA)	(kW)	(kVA)	(kW)
380/220	515	412	531	425
400/230	515	412	531	425
415/240	515	412	531	425

Notes:

PRIME POWER: Electrical power data available at a variable load without limits of hours per year. An overload of 10 % is allowed for 1 hour of every 12. In accordance with ISO 8528/1 (2005) – PRP

STANDBY POWER: Electrical power data at variable load in an emergency in accordance with standard ISO 8528/1 (2005) – ESP. Overloads of emergency power are not allowed.

The standard reference conditions are: 25 °C, 100 kPa and 30% relative humidity. Diesel density: 0.835 g/cm3.

General description

Specifically developed for the industrial applications, this soundproof generator set is easy to use and straightforward to maintain. The available features & options are designed to fully meet the requirements of all industrial applications. The generator set will automatically start on mains failure and cool down and stop as soon as the mains come back. The generator set also controls the load transfer between mains (utility) and generator set. It can also be start-up by means of an external signal.

It's your solution for Predictable Power.

Engine

CUMMINS diesel 4 stroke engine, with direct injection and electronic regulation of the engine speed.

Engine brand	Cummins	Engine Capacity (l)	13.00
Model	QSZ13-G3	Bore (mm)	130
R.P.M.	1500	Stroke (mm)	163
Fuel	Diesel	Compression ratio	0.71
No. of cylinders	6	Type of regulation	Electronic

Cooling System

Cooling of the sleeves using cooling fluid comprised of water and glycol at 50% in a closed circuit driven by the engine pump.

The circuit is completed with a blower fan driven by the engine, radiator, expansion tank, cooling fluid purge system towards the outside of the bedplate and protections of all the running surfaces.

Cooling type	Water	Limit ambient temperature (°c)	40
Coolant capacity (l)	55		

Coolant heater with heating element is available as an option. An adjustable thermostat is included to maintain the temperature at optimum range and facilitate the starting of the engine.

Coolant heater power (W)	1 x 4000W		
---------------------------------	-----------	--	--

Lubrication System

The lubrication system of this diesel engine comprises the oil pan, oil filter, oil switch and gear oil pump driven by the engine. All the components are original from the engine manufacturer.

It can be completed by an optional manual oil sump drain pump.

Oil capacity (l)	71		
-------------------------	----	--	--

Air intake system

Air intake system for combustion with filtering device and filter change indicator; originals from the engine manufacturer. Intake air cooling after the turbo by means of an air/air exchanger.

Intake air flow (m³/min)	30.3		
--	------	--	--

Exhaust System

The exhaust system consists of pipes, bellow, interior and exterior aluminized steel exhaust silencer that is highly resistant to corrosion, rain cap and hot part protections.

T^a gas emission (°C)	547	Engine Capacity (c.c.)	13.00
Gas flow (m3/min)	86.7	Outlet diameter (")	6
Number of exhaust	1		

Start System

Start system that uses an electrical motor, battery and battery charge alternator that is driven by the engine itself. The start motor and the battery charge alternator are originals from the engine manufacturer.

Starter voltage system (V)	24	Battery type	2 x 12V 200Ah
-----------------------------------	----	---------------------	---------------

Fuel supply system

The fuel system consists of a fuel tank, feed pump, water separator fuel filter including 30 microns filtering element, injection pump and injection nozzles.

The fuel tank is made from plastic to prevent rust and includes a filling connection with cap and key, a cleaning hatch and draining plug for easier maintenance. The fuel level is controlled thanks to a fuel level sensor with an analogue gauge mounted in the control cubicle.

Fuel tank capacity (L)	740
-------------------------------	-----

Fuel consumption panel

(range according to the standard configuration)

Load	Prime Power (PRP)		Standby Power (ESP)	
	(l/h)	Range (h)	(l/h)	Range (h)
0%	9.1	81	9.1	81
50%	52	14	53.5	14
75%	76.1	10	78	9
100%	105.4	7	110	7

Alternator

Atlas Copco alternator with 4 poles, with a lifetime lasting greased bearing, H class insulation, without brushes, 2/3 pitch and AVR (Automatic Voltage Regulator)

Protection of all the windings by means of 2-part high quality polyester resin impregnation. The stator windings receive a double impregnation. Final finish with a coat of EG43 varnish.

Shunt excitation system that provides overload of 1,6 times the nominal current. The auxiliary winding as optional with overload capacity 3 times the nominal current for 20 s.

Joining of engine and alternator through flexible disc coupling.

Regulations:

- IEC 60034
- GB 755
- VDE 0530
- BS 5000
- NEMA MG1-22
- ISO 8528:3

Low wave distribution:

- THC < 5%
- THD < 5%
- THF (IEC) < 2%
- TIF (NEMA) < 50

Incorporates electromagnetic emissions suppressor in accordance with standard VDE 0875, class K.

Engine brand	Atlas Copco	Voltage Stability	±1%
Model	ACA355C	Performance at 75% p.f. 0.8 (%)	95
Alternator Power (kVA)	550	Performance at 100% p.f. 0.8 (%)	94
Number of wires	12	Direct subtransient reactance X''d (%)	0.10
IP Alternator	IP 23	Subtransient time constant, T''d (ms)	0.012
Excitation system	SHUNT	Zero sequence reactance, Xo (%)	0.09
AVR model	AS440	Short-circuit ratio, Kcc	0.37

Bed plate

The engine-alternator set is coupled to the bedplate by means of anti-vibration shock mounts that absorb almost all the vibrations.

The base frame is able to hold 100% of the liquids of the genset, reducing any potential environmental impact. It has a drainage plug.

Sound proofed canopy

The canopy includes an external access to the lifting beam and push to close latches with key.

The lifting beam is available as an option.

It is lined inside with a noise-absorbing material of polyurethane foam with a 30 mm thick waterproof protector veil with a density of 25 kg/m³. It also has an emergency shutdown pushbutton that is accessible from the outside.

Electric panel

Easily accessed control cubicle integrated in the generator set with digital controller providing advanced engine monitoring and protection features. Performance and maintenance requirements can also be observed. The cubicle includes multi-poles thermal-magnetic protection circuit breaker against overloads and short-circuits.

Has a circuit breaker, manually actuated, with thermal-magnetic protection against overloads and short-circuits.

Circuit Breaker rated current (A)	800A 4P R	Battery charger	DSE 9255 - 24V 5A
--	-----------	------------------------	-------------------

Has a DEEP SEA battery charge maintainer, designed to be permanently connected to the battery and maintains it charged to its maximum capacity.

Has no moving parts. The charger switches to floating mode when the charge is complete

Control Card

DEEP SEA control plate, DES 7320 with grid monitor that starts-up the generator set when it detects a failure in the electrical power supply from the grid and sends a signal to the switching panel to switch from the grid position to the group position . Once the power supply has been re-established, it sends an order to the switching panel to transfer the generator set power to the grid and shuts-down the generator set once it has cooled down. It also starts-up the generator set using an external signal.

Also, control plate DES 7320 checks a large number of parameters of the generator set which allows it to display information, statuses and alarms. If required, it will shutdown the generator set: Due to high coolant fluid temperature, low oil pressure, low coolant fluid level, etc.

Includes a LCD screen with lighting, 5 navigation menubuttons, independent operational mode buttons, and alarms and status indicating LEDs, support 7 languages.

Communications via USB, and Completely configurable using a PC in Windows environment and free Scada type software in real time.

Includes reading and displaying of parameters with RMS values, real time clock, events history log up and programming of alarms, events, start-ups and shutdowns.

Operating modes: START-UP, SHUTDOWN, AUTO, MANUAL AND TEST.

Generator

- Generator voltage (L-N)
- Generator voltage (L-L)
- Generator frequency
- Generator current
- kW
- kVA
- kWh
- kVAh
- Power factor



Grid

- Grid voltage (L-N)
- Grid voltage (L-L)
- Grid frequency

Engine

- Turn speed
- Cooling fluid temperature
- Oil pressure
- Hour meter
- Battery voltage
- No. of start-ups
- Fuel level

Protections

- Start-up fault (generator set shutdown)
- High coolant temperature (alarm and generator set shutdown)
- Low oil pressure (alarm and generator set shutdown)
- Low fuel level (alarm)
- Low cooling fluid level (generator set shutdown)
- Overload (alarm and generator set shutdown)
- Battery voltage high (alarm)
- Battery voltage low (alarm)
- Battery charge alternator failure (alarm)
- Generator low frequency (alarm and shutdown)
- Generator high frequency (alarm and shutdown)
- Generator low voltage (alarm and shutdown)
- Generator high voltage (alarm and shutdown)
- External emergency shutdown (shutdown)
- Engine overspeed (shutdown)
- Maintenance interval (alarm)

PTB

Optional Cabinet for switching between the grid and the generator set by means of Socomec brand power transfer switch with an integrated mechanical and electrical interlocking device.

Allows for the padlock locking function. Includes a Manual / Automatic mode selector and emergency manual control. Safety switching for isolating the loads. High dynamic resistance against short-circuits.

Position indicator with fully visualized cut-off. Stable positions not affected by changes in voltage and mechanical vibrations. External electrical control of the positions and test sequences.

High number of operations. IP54 protection. Connections: Lower/lower.

PTB	PTB 4P 800A 160-333V L-N 50-60Hz
------------	----------------------------------

Dimensions and weight

Fuel Tank Capacity	
Length, L (mm)	4600
Width, A (mm)	1500
Height, H (mm)	2350
Net Weight (kg)	5100
Capacity Fuel Tank (l)	740

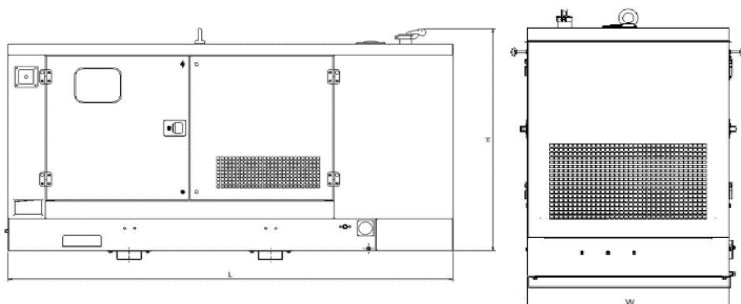

Performance class

Execution class in accordance with ISO 8528/5 (2005) taking into account the behaviour of the generator set in a permanent mode of operation with different load levels, as well as in a temporary mode of operation due to shocks in the load.

Performance class	G3
--------------------------	----

Applicable international regulations:

- ISO 8528
- ISO 3046
- BS 5000
- IEC 60034